

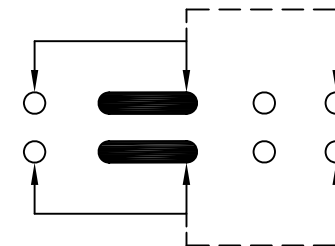

CAD FILE:

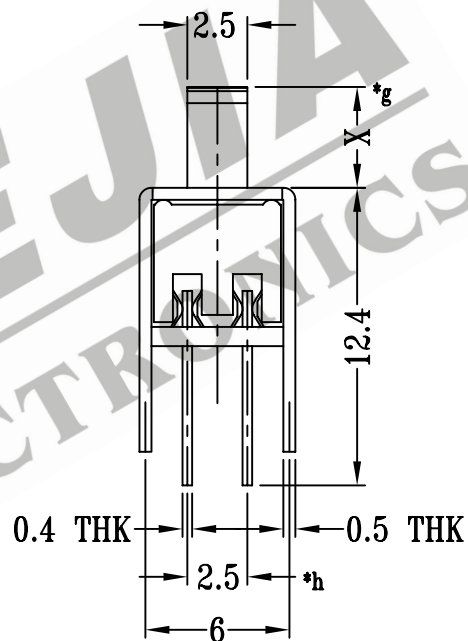

SCHEMATIC (NON-SHORTING)

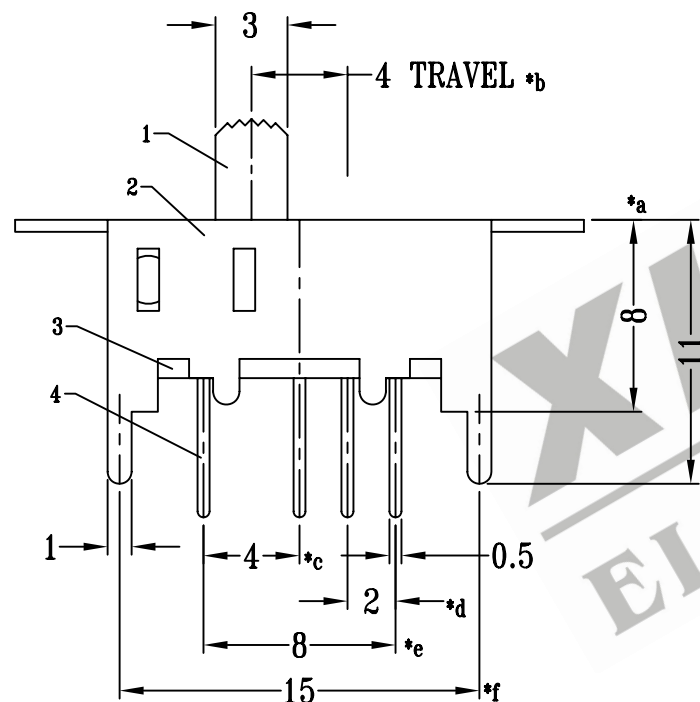
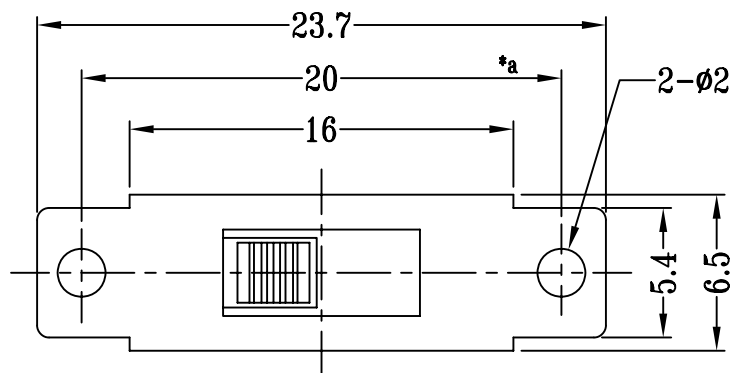
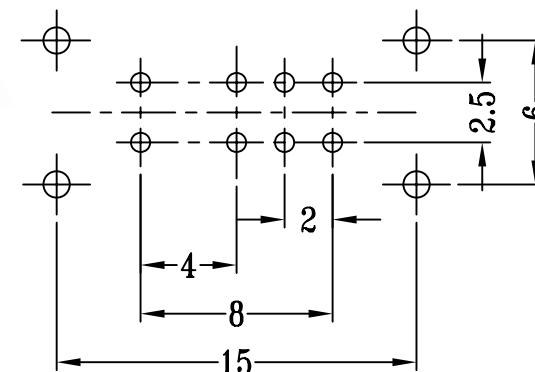

P.C.B LAYOUT

注:带*表示关键尺寸(8个)

NO.	PARTS	MATERIALS	Q'TY	FINISH	TOLERANCE UNLESS SPECIFIED	SHENZHEN XIEJIA ELECTRONICS CO.,LTD.				
8										
7	STEEL BALL	STEEL	1	NATURAL						
6	SPRING	STEEL WIRE	1	TEMPER						
5	CONTACT CLIP	PBS STRIP	2	Ag PLATED	WITHIN: 1.5±0.1mm OVER: 1.5±0.2mm	ISSUE	DATE	DESCRIPTIONS OF REVISION		APPD.
4	TERMINAL	BRASS STRIP	8	Ag PLATED OVER Ni PLATED	TITLE: VERTICAL SLIDE SWITCH		UNIT: mm	DRWG NO.: XJ-DR-SS22H04-00		
3	BASE	PHENOLIC RESIN	1	NATURAL	MODEL: SS-22H04		SCALE: 3:1	DWN.	ZHOUYU	2002-9-17
2	FRAME	STEEL STRIP	1	Ni PLATED	ALL MATERIALS MUST BE COMPLIANT TO ROHS			CHK'D	FANGYING	2002-9-17
1	KNOB	POM	1	BLACK				APPD.	KANGXINAN	2002-9-17